

Raum 202/203

Hoval-Haus
General Wille-Str. 201
8706 Meilen

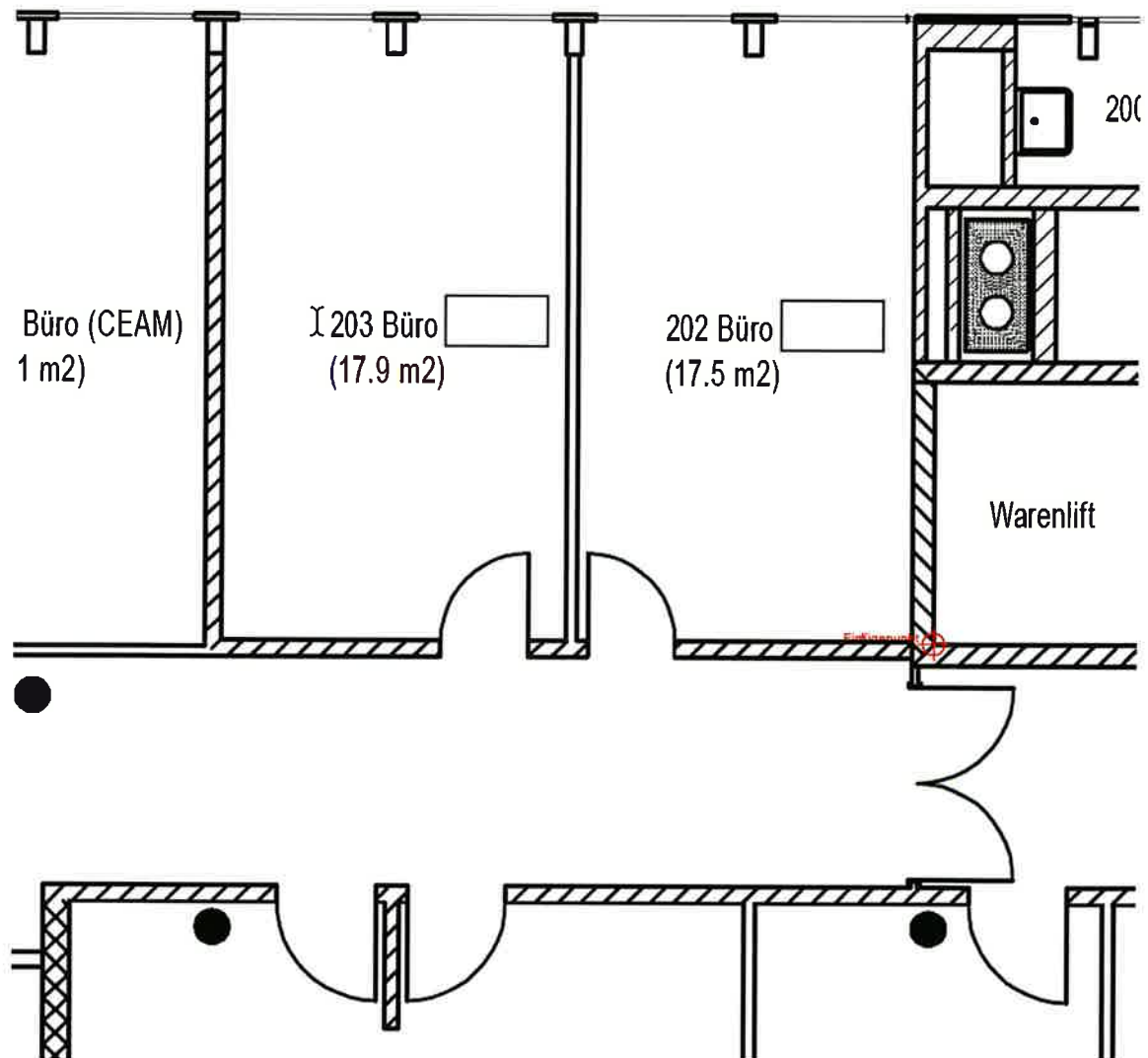

2. OG ca 36 m2

Preis monatl.: Miete CHF 960.00 + Reinigung Infra CHF 25.00 = CHF 985.00 excl. MWST

Parkplatz monatl CHF 60.00 aussen, CHF 130.00 innen excl. MWST

Raum 310

Hoal-Haus
General Wille-Str. 201
8706 Meilen

301 Treppenhaus

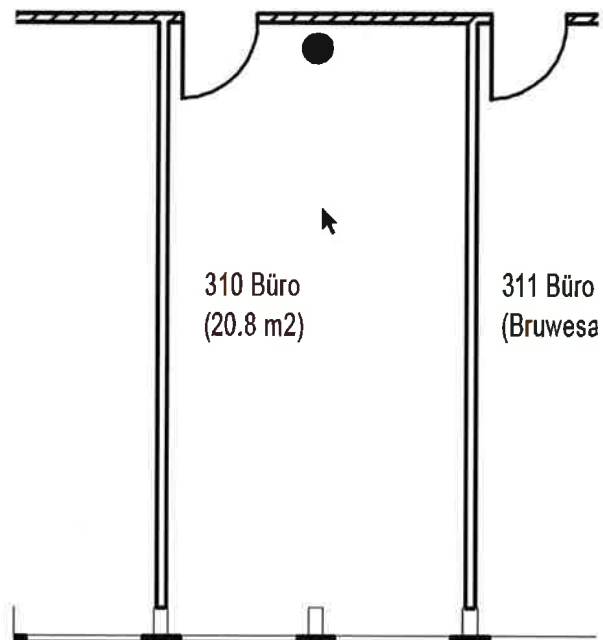
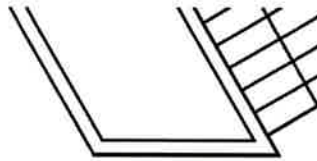

3. OG ca 21 m2

Preis monatl.: Miete CHF 500.00 + Reinigung Infra CHF 25.00 + Anteil Heizung/Klima (pausch.) CHF 40.00 = CHF 565.00 excl. MWST

Parkplatz monatl CHF 60.00 aussen, CHF 130.00 innen excl. MWST

Raum 365

Hoval-Haus
General Wille-Str. 201
8706 Meilen

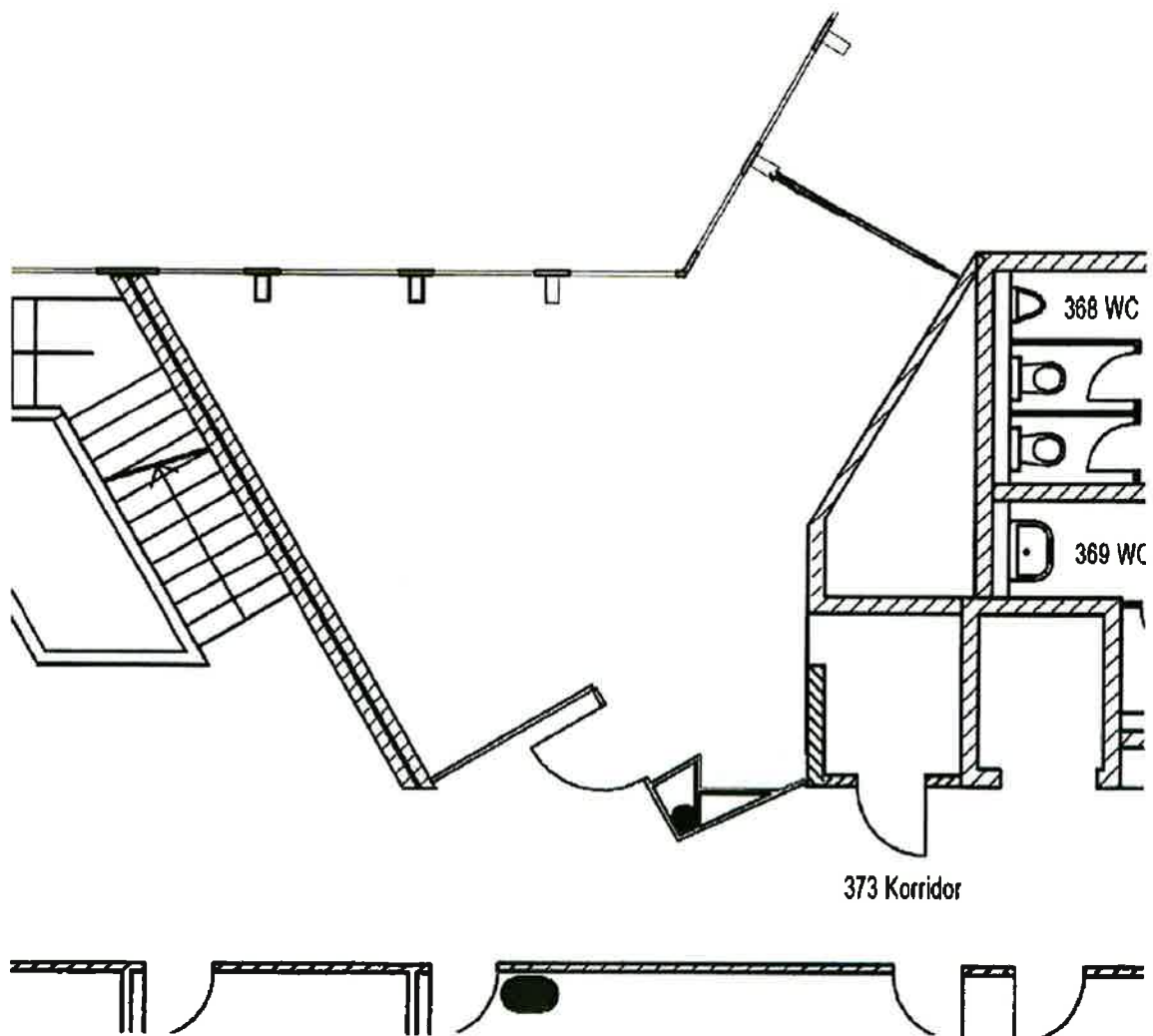

3. OG ca 40 m²

Preis monatl.: Miete CHF 1000.00 + Reinigung Infra CHF 50.00 + Anteil Heizung/Klima (pausch.) CHF 80.00 = CHF 1'130.00 excl. MWST

Parkplatz monatl CHF 60.00 aussen, CHF 130.00 innen excl. MWST